



**4/69-71 Parramatta Street CRONULLA NSW**

2 1 1

Enjoying a sundrenched north east aspect, this 1st floor apartment enjoys the ultimate beachside locale and is conveniently positioned in an immaculately maintained security complex only a short stroll to all of South Cronulla's famous attractions.

Features are:

- 2 well proportioned bedrooms
- Eat-in kitchen with dishwasher
- Large internal laundry with w.c.
- Modern bathroom
- Quality security complex
- Single lock up garage with internal entry
- Sundrenched wraparound balcony

[For full version visit the website](https://www.burkeproperty.com.au/7404232)

**Type** : Apartment  
**View** : <https://www.burkeproperty.com.au/7404232>



**David Kennedy**  
02 9544 1111

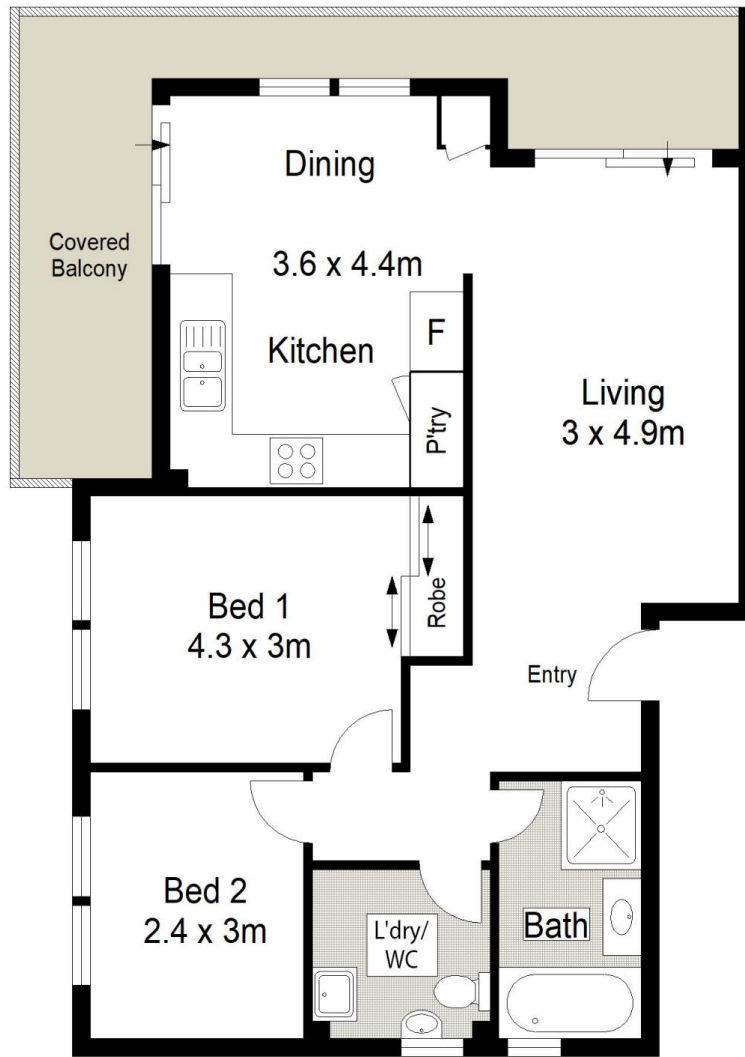

**FIRST FLOOR**

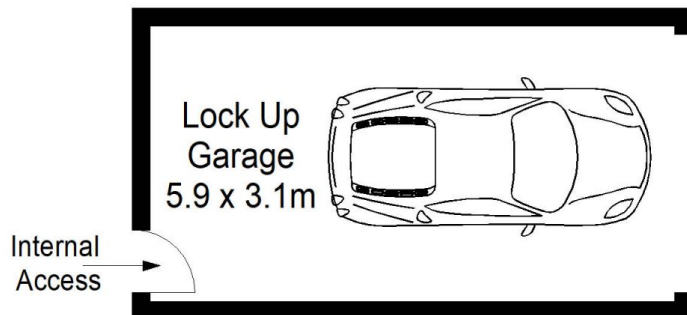

**GROUND FLOOR**

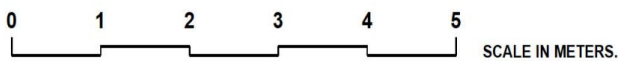

Scale in metres. Indicative only. Dimensions are approximate. All information contained herein is gathered from sources we believe to be reliable. However we cannot guarantee its accuracy and interested persons should rely on their own enquiries.

