



## 14/6 Burraneer Bay Road CRONULLA NSW

2 1 1

Situated only metres to Gunnamatta bay, railway station, Cronulla mall and restaurants, this top floor 2 bedroom apartment is ideal for 1st home buyers or the astute investor.

**Type** : Apartment

**View** : <https://www.burkeproperty.com.au/7404236>

Features are:

- Privately positioned at the rear of the complex
- Combined lounge/dining with floorboards
- 2 well proportioned bedrooms
- Main bedroom with built-in robe
- Modern bathroom with bath
- Open plan kitchen with dishwasher
- Undercover car space/carport
- Easy walk to all of Cronulla's attractions



**David Kennedy**  
02 9544 1111

[For full version visit the website](https://www.burkeproperty.com.au)

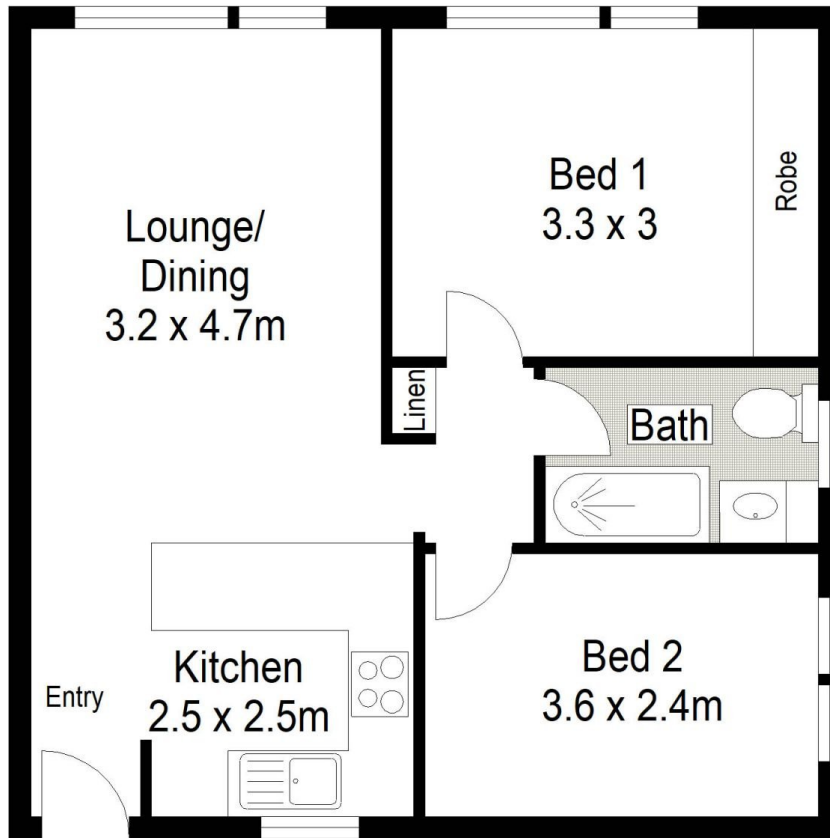

**TOP FLOOR**

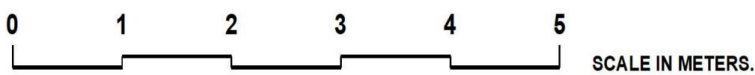
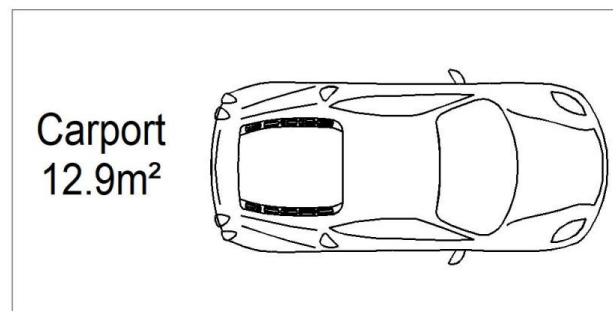

Scale in metres. Indicative only. Dimensions are approximate. All information contained herein is gathered from sources we believe to be reliable. However we cannot guarantee its accuracy and interested persons should rely on their own enquiries.

